

ITEM NO.	PART NUMBER	DESCRIPTION	QTY.	WEIGHT [kg]	WEIGHT [lbs]
1	AB88-046Wnar	FRAME HOLDER	2	29.2	64.2
2	AB88-0151W	MAIN HOLDER	2	61.6	135.6
3	AB88-033W	LEG W/NUT	4	28.4	62.4

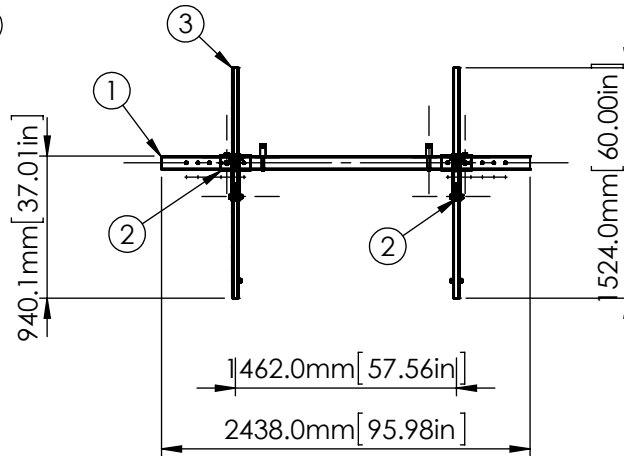
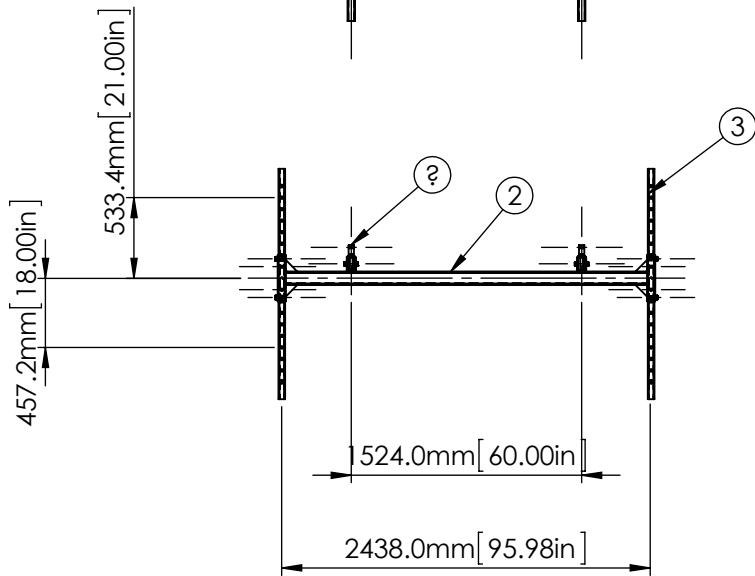
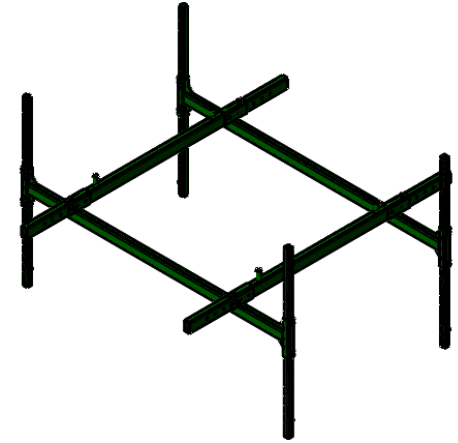
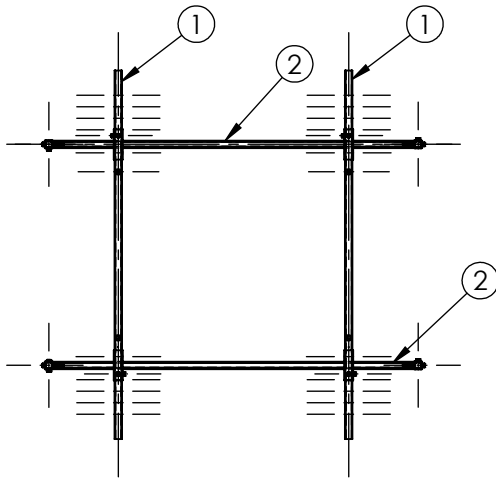

PROPRIETARY AND CONFIDENTIAL
 THE INFORMATION CONTAINED IN THIS DRAWING IS THE SOLE PROPERTY OF SCAFFOLDMART. ANY REPRODUCTION IN PART OR AS A WHOLE WITHOUT THE WRITTEN PERMISSION OF SCAFFOLDMART IS PROHIBITED.

		DIMENSIONS ARE IN mm		NAME	DATE
		TOLERANCES:		DRAWN	BALAS 09/10/2013
		ONE PLACE DECIMAL ±0.3		CHECKED	G. SMITH
		TWO PLACE DECIMAL ±0.03		ENG APPR.	G. SMITH
		THREE PLACE DECIMAL ±0.015		MFG APPR.	
		MATERIAL --		Q.A.	
		FINISH --		LAST SAVED DATE: Tuesday, September 10, 2013 6:30:01 PM	
NEXT ASSY	USED ON	COMMENTS:			
APPLICATION		DO NOT SCALE DRAWING			

SCAFFOLDMART 1705 S. Evans St. Greenville, NC 27834		
DWG. TITLE ADJUSTABLE BASE LAYOUT		
SIZE A	DWG. NO. AB88-01nar	REV.
SCALE: 1:50 WEIGHT: 119.2 kg, 262.2 lbs SHEET 1 OF 1		